

SCHWARZBECK MESS - ELEKTRONIK

An der Klinge 29 D-69250 Schönau Tel.: 06228/1001 Fax.: (49)6228/1003

VHF-UHF Balun / Halter UBAA 9114 mit Offenkonusen BAOC 9216 VHF-UHF Balun / Holder UBAA 9114 with Open Cone Elements BAOC 9216

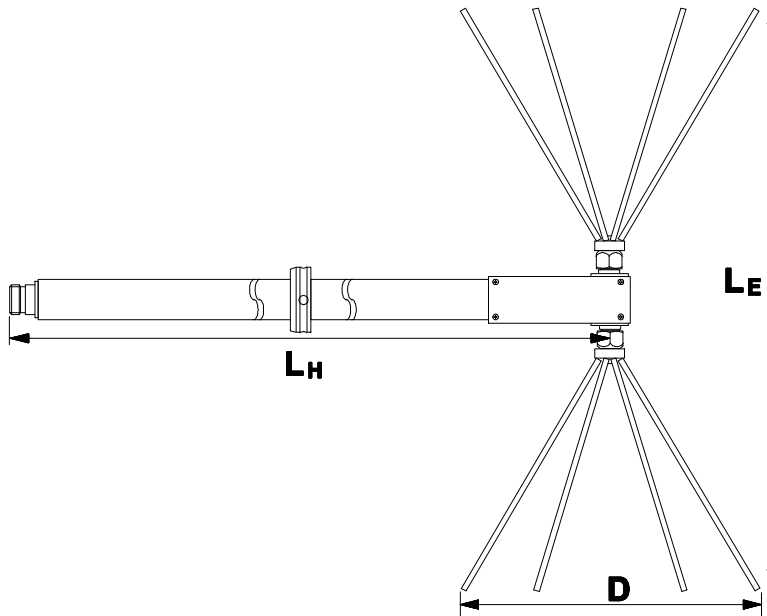

LE = 276 mm, D = 155 mm

Frequency MHz	Distance m	lambda m	Attenuation dB	Gain(Isotr.) dBi	Gain(Dipole) dBd	Ant.-Factor dB/m
30.00	2.50	10.00	84.40	-37.23	-39.38	36.99
35.00	2.50	8.57	81.93	-35.32	-37.47	36.43
40.00	2.50	7.50	80.40	-33.98	-36.13	36.24
45.00	2.50	6.67	77.92	-32.23	-34.38	35.51
50.00	2.50	6.00	75.40	-30.51	-32.66	34.71
60.00	2.50	5.00	70.60	-27.32	-29.47	33.10
70.00	2.50	4.29	66.95	-24.82	-26.97	31.94
80.00	2.50	3.75	63.58	-22.56	-24.71	30.84
90.00	2.50	3.33	60.98	-20.75	-22.90	30.05
100.00	2.50	3.00	58.45	-19.02	-21.17	29.24
110.00	2.50	2.73	56.19	-17.48	-19.63	28.53
120.00	2.50	2.50	54.30	-16.16	-18.31	27.96
130.00	2.50	2.31	52.48	-14.90	-17.05	27.40
140.00	2.50	2.14	50.75	-13.71	-15.86	26.85
150.00	2.50	2.00	49.40	-12.74	-14.89	26.48
160.00	2.50	1.88	48.10	-11.81	-13.96	26.11
170.00	2.50	1.76	46.85	-10.92	-13.07	25.75
180.00	2.50	1.67	46.10	-10.30	-12.45	25.62
190.00	2.50	1.58	45.27	-9.65	-11.80	25.44
200.00	2.50	1.50	44.47	-9.02	-11.17	25.26
Frequency MHz	Distance m	lambda m	Attenuation dB	Gain(Isotr.) dBi	Gain(Dipole) dBd	Ant.-Factor dB/m

SCHWARZBECK MESS - ELEKTRONIK

An der Klinge 29 D-69250 Schönau Tel.: 06228/1001 Fax.: (49)6228/1003

VHF-UHF Balun / Halter UBAA 9114 mit Offenkonusenlementen BAOC 9216 VHF-UHF Balun / Holder UBAA 9114 with Open Cone Elements BAOC 9216

Frequency	Distance	lambda	Attenuation	Gain(Isotr.)	Gain(Dipole)	Ant.-Factor
MHz	m	m	dB	dBi	dBd	dB/m
210.00	2.50	1.43	43.90	-8.53	-10.68	25.19
220.00	2.50	1.36	43.07	-7.91	-10.06	24.98
230.00	2.50	1.30	42.39	-7.38	-9.53	24.83
240.00	2.50	1.25	41.75	-6.87	-9.02	24.70
250.00	2.50	1.20	40.90	-6.27	-8.42	24.45
260.00	2.50	1.15	40.17	-5.73	-7.88	24.25
270.00	2.50	1.11	39.62	-5.29	-7.45	24.14
280.00	2.50	1.07	38.85	-4.75	-6.90	23.91
290.00	2.50	1.03	38.20	-4.27	-6.43	23.74
300.00	2.50	1.00	37.47	-3.76	-5.91	23.52
325.00	2.50	0.92	36.22	-2.79	-4.94	23.25
350.00	2.50	0.86	35.18	-1.95	-4.10	23.05
375.00	2.50	0.80	34.10	-1.11	-3.26	22.81
400.00	2.50	0.75	33.12	-0.34	-2.49	22.60
425.00	2.50	0.71	32.60	0.19	-1.97	22.60
450.00	2.50	0.67	32.50	0.48	-1.67	22.80
475.00	2.50	0.63	32.98	0.48	-1.67	23.27
500.00	2.50	0.60	33.75	0.32	-1.83	23.88
525.00	2.50	0.57	34.47	0.17	-1.98	24.45
550.00	2.50	0.55	36.25	-0.52	-2.67	25.55
575.00	2.50	0.52	38.32	-1.36	-3.51	26.77
600.00	2.50	0.50	39.65	-1.84	-3.99	27.62
625.00	2.50	0.48	41.27	-2.47	-4.63	28.61
650.00	2.50	0.46	42.95	-3.14	-5.29	29.62
675.00	2.50	0.44	44.77	-3.89	-6.04	30.70
700.00	2.50	0.43	46.30	-4.50	-6.65	31.62
725.00	2.50	0.41	47.30	-4.84	-7.00	32.27
750.00	2.50	0.40	48.12	-5.11	-7.26	32.83
775.00	2.50	0.39	49.34	-5.57	-7.73	33.58
800.00	2.50	0.38	49.72	-5.63	-7.78	33.91
825.00	2.50	0.36	50.25	-5.76	-7.91	34.31
850.00	2.50	0.35	51.20	-6.10	-8.25	34.91
875.00	2.50	0.34	51.68	-6.22	-8.37	35.28
900.00	2.50	0.33	51.55	-6.03	-8.18	35.34
925.00	2.50	0.32	52.38	-6.33	-8.48	35.87
950.00	2.50	0.32	52.75	-6.40	-8.55	36.17
975.00	2.50	0.31	52.80	-6.31	-8.46	36.31
1000.00	2.50	0.30	53.20	-6.40	-8.55	36.62
Frequency	Distance	lambda	Attenuation	Gain(Isotr.)	Gain(Dipole)	Ant.-Factor
MHz	m	m	dB	dBi	dBd	dB/m

SCHWARZBECK MESS - ELEKTRONIK

An der Klinge 29 D-69250 Schönau Tel.: 06228/1001 Fax.: (49)6228/1003

VHF-UHF Balun / Halter UBAA 9114 mit Offenkonusen BAOC 9216
VHF-UHF Balun / Holder UBAA 9114 with Open Cone Elements BAOC 9216

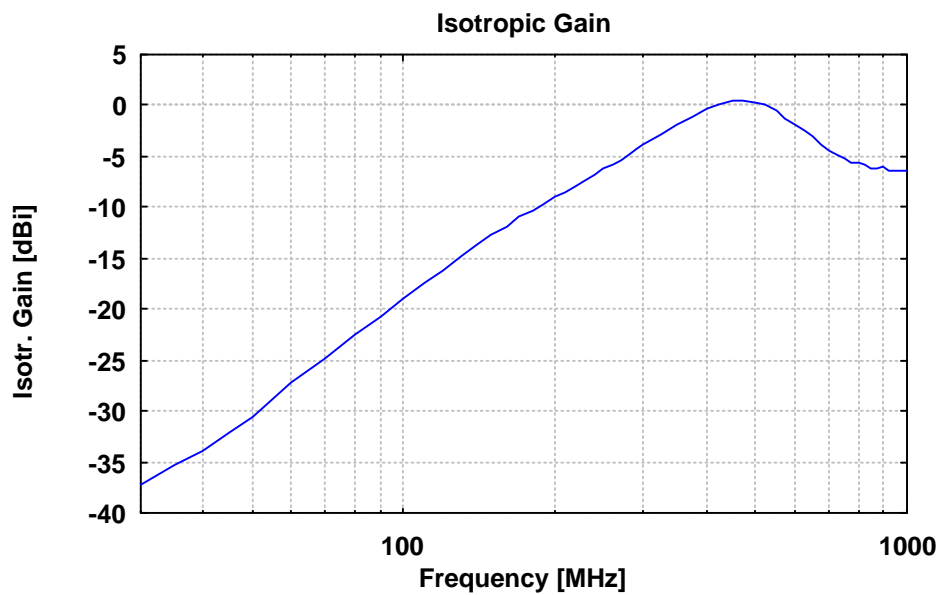
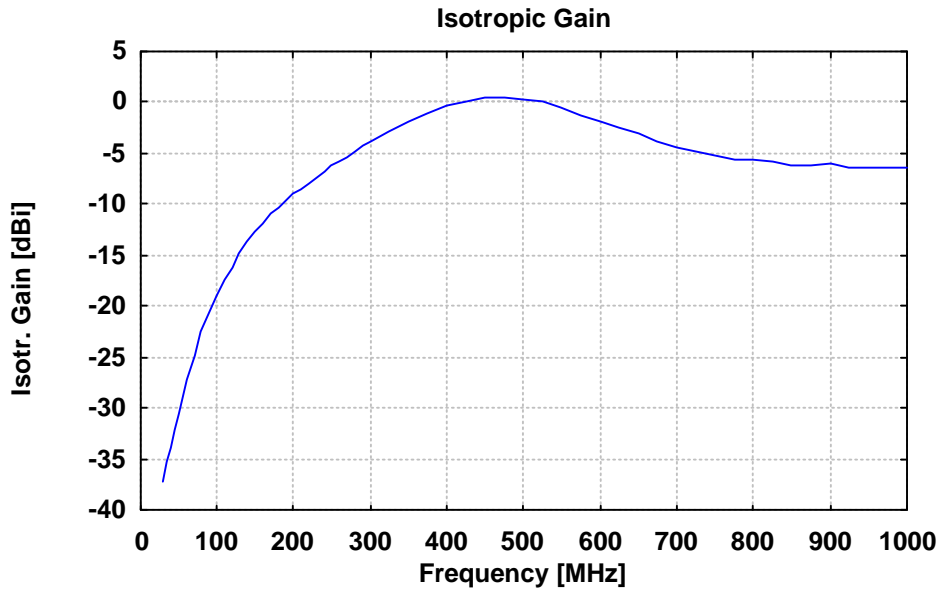

UBAA 9114 / BAOC 9216 (small open-cone elem., 01214) Isotropgewinn / Isotropic Gain dBi

SCHWARZBECK MESS - ELEKTRONIK

An der Klinge 29 D-69250 Schönau Tel.: 06228/1001 Fax.: (49)6228/1003

VHF-UHF Balun / Halter UBAA 9114 mit Offenkonusenlementen BAOC 9216
VHF-UHF Balun / Holder UBAA 9114 with Open Cone Elements BAOC 9216

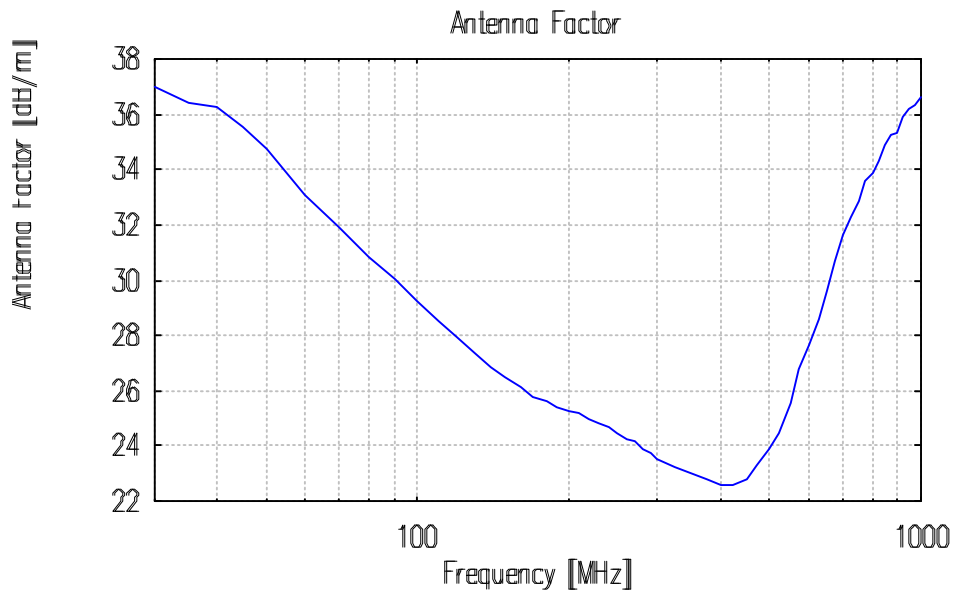
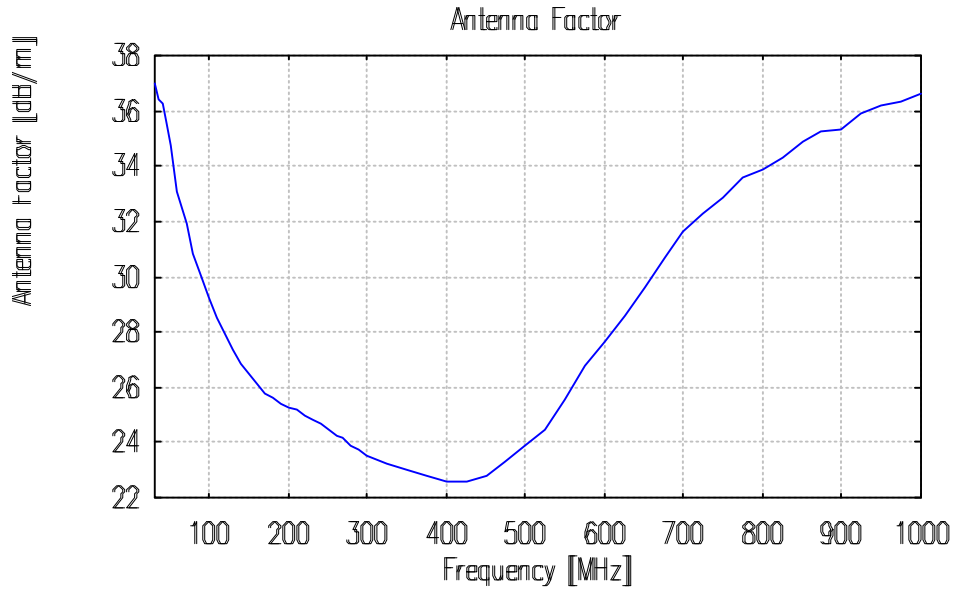

UBAA 9114 / BAOC 9216 (small open-cone el., 01214) Antennen-Wandlungsmaß *Ant. Factor*
dB/m